

Translation

Supplemental requirements for the testing and certification of heat-protective gloves used to protect against the thermal effects of electric fault arcs

Status as of 2019-02

Energy, textile & electrical media products department
Testing and certification facility in DGUV Test
Gustav-Heinemann-Ufer 130
50968 Cologne, Germany

GS-ET 42-2

These principles will be revised and supplemented periodically in consideration of knowledge gained in the area of occupational health and safety, as well as technical progress. The most recent edition shall always be binding for the tests conducted and the certifications issued by the testing and certification body of the committee for electrical engineering in DGUV TEST.

These supplemental requirements compliment the requirements from

- DIN EN 407:2004-11, „Protective gloves against thermal risks (heat and/or fire)“

in order to achieve conformity with PPE Regulation (EU) 2016/425.

Note:

The testing of thermal protection according to Sec. 4.2 of these Principles is based upon DIN EN 61482-1-2:2015-08.

This is the English translation of the German test principle. The German original version is obligatory.

Table of Contents

	<u>Page</u>
1 General	5
1.1 Scope of application	5
1.2 Testing and/or certification process.....	5
2 Terms 5	
2.1 Protective glove	5
2.2 Heat-protective gloves with additional electric fault arc protection.....	5
2.3 Arc protection class (APC)	5
3 Requirements and tests.....	5
3.1 General	5
3.2 Documents to be submitted.....	6
3.3 Test specimens.....	6
4 Supplemental requirements/Tests.....	6
4.1 Flame resistance	6
4.1.1 Test of burning behaviour.....	6
4.1.2 Flame resistance, materials.....	7
4.1.3 Flame resistance, seams.....	7
4.2 Thermal protection (electric arc testing)	7
4.2.1 Test apparatus.....	7
4.2.2 Test box.....	7
4.2.3 Glove test panel with calorimeter	7
4.2.3.1 Sensor installation	7
4.2.3.2 Sensor response.....	7
4.2.4 Electrical supply and electrodes	8
4.2.4.1 Electric test circuit.....	8
4.2.4.2 Test circuit control.....	8
4.2.4.3 Electrodes	8
4.2.4.4 Fuse wire	9
4.2.5 Electric test arc characteristics	9
4.2.6 Data acquisition system.....	9
4.2.7 Preparing the test specimen	9
4.2.8 Calibration.....	10
4.2.8.1 Measurement chain for temperature acquisition	10
4.2.8.2 Calibration of the electric test circuit.....	10
4.2.8.3 Confirmation of test apparatus settings.....	10
4.2.8.4 Preparing and conditioning the box.....	11

4.2.9	Maintenance and care of the test apparatus	11
4.2.9.1	Care of the sensor surface	11
4.2.9.2	Care of the glove test panel.....	12
4.2.9.3	Care of the electrodes	12
4.2.10	Test procedures.....	12
4.2.10.1	Test apparatus.....	12
4.2.10.2	Number of test specimens.....	12
4.2.10.3	Test parameters.....	12
4.2.10.4	Test conditions and initial temperature.....	13
4.2.10.5	Mounting the test specimen.....	13
4.2.10.6	Performing the test	13
4.2.10.7	Evaluation of measurement results	14
4.2.10.8	Sensor response versus Stoll curve	14
4.2.10.9	Assessment of test results.....	14
4.3	Additional marking & identification.....	15
4.4	Durability of markings	15
4.5	User information	15
4.6	External materials and properties.....	16
4.6.1	PAH	17
4.6.2	DMF	17
5 Annexes	20	
5.1	Directives / Regulations.....	20
5.2	Standards	20

1 General

1.1 Scope of application

These supplemental requirements are applicable for heat-protective gloves worn when working where a risk of electric arcing exists.

1.2 Testing and/or certification process

The testing and certification process will be initiated upon signing of the contract by the contractual partners. The technical documentation set forth in Section 3.2 is to be submitted together with the contract.

2 Terms

2.1 Protective glove

An item of personal protective equipment (PPE) that protects the hand or a part of the hand against injury, which is worn to supplement other protective equipment (e.g. protective clothing, face shield, etc.).

It can also be used to protect the forearm or the entire arm.

2.2 Heat-protective gloves with additional electric fault arc protection

Protective gloves that protect the hands against heat and/or fire, while providing additional protection against the thermal effects of electric fault arcs.

They are worn when the hazard of an electric fault arc exists.

2.3 Arc protection class (APC)

The category of electric arc testing, as distinguished by the test distance and the test energy level.

NOTE: As opposed to clothing, these Principles of testing incorporate two additional protection classes in order to allow a shorter distance between the hands (150 mm) and the electric fault arc source.

NOTE: These two additional protection classes are valid only for the gloves described in these Principles of testing.

3 Requirements and tests

3.1 General

Heat-protective gloves with additional electric fault arc protection must conform to the basic requirements set forth in DIN EN 407:2004-11.

Moreover, the respective supplemental requirements set forth in these Principles of testing apply as well.

Insofar as it has not been set forth in the individual test sections, the tests are to be carried out at an ambient temperature between 15°C and 35°C and a relative humidity from 25% to 75%.

3.2 Documents to be submitted

The following technical documentation is required for testing:

- User information including technical specifications
- Parts lists
- Data sheets for the materials used
- Product drawings including measurements
- Production documents
- EU Declaration of Conformity

For EU type-examinations according to PPE regulations, the technical documentation must be submitted in accordance with Annex III of the PPE regulation.

3.3 Test specimens

For tests carried out according to these Principles of testing, 4 pairs (8 test specimens) in size 10 will be required for each type of protective glove.

4 Supplemental requirements/Tests

4.1 Flame resistance

4.1.1 Test of burning behaviour

Testing is carried out according to DIN EN ISO 6941 with the following exceptions:

- the glove should be positioned vertically so that Point A (Fig. 1) is at the centre of the lower edge.

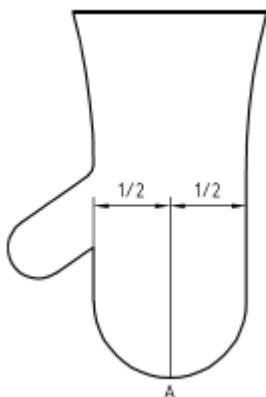

Fig. 1 - Test apparatus

The burner shall be positioned beneath and in front of the glove so that it is in line with the glove's vertical centreline or middle finger and perpendicular to the glove surface. At the same time, the burner's longitudinal axis is angled $(30 \pm 3)^\circ$ from a vertical alignment. The distance between the torch tip and the lower end of the glove or middle finger must be (20 ± 2) mm. One protective glove is to be tested for each flame exposure test according to 4.1.1 and 4.1.2.

4.1.2 Flame resistance, materials

With a flame exposure time of 3 s, the glove materials used to protect against the thermal effects of electric fault arcs must fulfil the burning behaviour requirements according to DIN EN 407 at Performance level 4 (afterflame time ≤ 2 s and afterglow time ≤ 5 s).

Furthermore, the material shall not melt or show flaming debris. The innermost glove layer must be inspected. It shall not show any signs of melting, as otherwise the test will be considered as not passed.

4.1.3 Flame resistance, seams

With a flame exposure time of 15 s, the seam exposed to the flame shall not break. Seamless gloves do not require this test.

4.2 Thermal protection (electric arc testing)

4.2.1 Test apparatus

The test apparatus must comprise the following elements:

- Test box
- Glove test panel
- Electrical supply
- Data acquisition system

4.2.2 Test box

The test box conforming to Fig. 3 must be made of non-conductive, heat-resistant materials (e.g. plaster).

4.2.3 Glove test panel with calorimeter

The glove test panel is configured with 3 sensors, equipped with glove holders and is made of non-flammable, non-metallic materials. Nominal dimensions and details regarding construction are specified in Fig. 4.

4.2.3.1 Sensor installation

The sensor with a diameter of 60 mm consists of an insulating board and a calorimeter. The calorimeter according to Sec. 5.2 of ISO 9151:1995 consists of a round copper disc made of electrolytic copper with a diameter of 40 mm and a mass of (18 ± 1) g, as well as a type T thermocouple (copper-constantan). The thermocouple element made of copper-constantan wire (type T according to IEC 60584-1) shall be attached in such a manner that the constantan wire is located at the centre, while the copper wire is located outside of the disc. The disc is embedded in an Insulating board. The sensor shall be mounted flush with surface of the test plate or the glove test panel. The heat-absorbing copper disc surface must be covered with a thin layer of optically black colour with an emission factor > 0.9 .

4.2.3.2 Sensor response

The conversion of sensor measurement values from temperature rise in $^{\circ}\text{C}$ to thermal energy (incident energy) in units of kJ/m^2 shall be calculated by multiplying the delta temperature values by a constant factor of $5.52 \text{ kJ}/\text{m}^2 \text{ }^{\circ}\text{C}$.

NOTE: *The constant factor is based on an average value for the copper thermal capacity $C_p = 0.385 \text{ J/g } ^\circ\text{C}$ ($80 \text{ }^\circ\text{C}$) in the tested temperature range, which is multiplied by the mass of the copper disc equating to 18 g (resulting from a diameter of 40 mm and a thickness of 1.6 mm) and then divided by the disc's cross-sectional area of 12.56 cm^2 .*

4.2.4 Electrical supply and electrodes

4.2.4.1 Electric test circuit

The electrical supply must be able to provide an almost constant AC source voltage and a constant short-circuit current (symmetrical AC component) during a time interval equivalent to the arc duration. AC currents of 50 Hz and 60 Hz are permissible.

The electric test circuit shall be set so that

- the test voltage and test current under idle conditions correspond to the voltage that would exist and current that would flow
- if the electrodes would be connected without impedance (short-circuit).

The arc tests shall be carried out at this setting.

4.2.4.2 Test circuit control

The test voltage and test current shall be verified by measurement. The test current (prospective short-circuit current) shall be recorded in the form of an oscillogram of the instantaneous values. These should be depicted graphically.

The closing and re-opening of the electric test circuit must be made with a circuit breaker that can be triggered according to the arc duration.

The X / R ratio should be in a range between 1 and 5.

NOTE: *There are no specific requirements with respect to closing the electric circuit (related to the respective current sine wave angle) and the phase angle or the X / R relationship of the source impedance.*

4.2.4.3 Electrodes

Two rod-shaped electrodes with a diameter of $25 \text{ mm} \pm 0.1 \text{ mm}$ shall be used. Electrodes featuring bores with a diameter of $14 \text{ mm} \pm 0.1 \text{ mm}$ at a depth of $20 \text{ mm} \pm 0.5 \text{ mm}$ or electrodes without bores can be used.

The upper electrode shall be made of unalloyed aluminium with a purity of at least 99.5%.

The lower electrode shall be made of electrolytic copper with a purity of at least 99.5%.

The end of the electrodes must be cut straight across in such a manner that the cut lies perpendicular to the electrode axis (see Fig. 3).

4.2.4.4 Fuse wire

A fuse wire connecting the ends of the opposing electrode tips shall be used to initiate the arc. This wire is consumed during the test. Therefore, its mass should be very small to reduce the burn risk due to molten metal. The fuse wire shall be a copper wire with a nominal diameter of maximum 0.5 mm.

4.2.5 Electric test arc characteristics

The characteristics of the electric arc are defined by the following parameters:

Test voltage: AC 400 V / +5%

Test current $I_{\text{arc, class}}$: Classes 1 and 3: 4 kA \pm 5%

Classes 2 and 4: 7 kA \pm 5%

Arc duration 500 ms \pm 5%

Frequency: Testing is to be carried out at a frequency of (50 \pm 0.1) or (60 \pm 0.12) Hz.

These parameters shall be compared during testing so the same parameters will be used for each test shot. The actual arc voltage, the actual arc current and the calculated actual arc power shall be recorded during the arc duration for each test shot.

4.2.6 Data acquisition system

Measurement and data acquisition:

The system shall be capable of simultaneously recording the test circuit current and voltage.

The sampling rate shall be at least 5 kHz.

The actual arc voltage, the actual arc current and the actual arc power shall be recorded for each test shot. These values shall be plotted in the protocol graph.

In addition to the voltage and current, the output from the calorimeter shall be recorded. Temperature data shall be acquired at a minimum sampling rate of 50 ms/channel for at least 30 s. The temperature acquisition system shall have at least a resolution of 0.1 °C.

4.2.7 Preparing the test specimen

4.2.7.1 The glove test panel shall be attached to a mount (e.g. table) in such a manner that the calorimeter is aligned opposite the centre of the glove holder at the specified electrode gap test distance and remains in position (Fig. 5) throughout the period of arc duration.

4.2.7.2 The test specimen shall be pre-conditioned at a temperature ranging between 18 °C and 28 °C and a relative humidity between 45% and 75% for at least 24 h.

4.2.7.3 If the manufacturer stipulates the use of undergloves, these are to be pre-conditioned in the same manner and tested together with the glove specimens.

NOTE: Although no separate requirements are stipulated for undergloves, they should be made of flame resistant materials.

4.2.8 Calibration

4.2.8.1 Measurement chain for temperature acquisition

The overall measurement chain, comprised of calorimeters and the data acquisition system, shall be calibrated on a regular basis.

For this, it must be possible to calibrate multiple temperature measuring points at levels above 100 °C.

4.2.8.2 Calibration of the electric test circuit

Calibration oscillograms of the prospective adjusted test current and the test voltage verifying the test conditions shall be recorded at least for each test series with unchanged test parameters.

The reference measurement shall be carried out by measuring the direct exposure incident energy E_{i0} without the test specimen.

Calibration of the test setup shall always be carried out on the test plate at a distance of $a = 300$ mm according to the standard settings in DIN EN 61482-1-2 for Arc protection class APC 1 or APC 2, irrespective of subsequent test distances (refer to Table 3). It shall be verified that the averaged energy E_{i0} of the two sensors on the test panel lies within a permissible deviation range around the mean value corresponding to Table 1 according to Fig. 3 of DIN EN 61482-1-2.

Arc protection class	Mean value E_{i0}	Permissible deviation range
	kJ/m ² (cal/cm ²)	kJ/m ² (cal/cm ²)
APC 1	146 (3.48)	± 28 (0.65)
APC 2	427 (10.185)	± 39 (0.95)

Table 1: Validity range of direct exposure incident energy

The arc energy values shall be determined for each individual calibration shot. A calibration shot is valid only if the arc energy W_{arc} lies within a permissible deviation from the mean values according to Table 2. Otherwise the calibration shot shall be repeated.

Arc protection class	Mean value W_{arc}	Permissible deviation range
	kJ	kJ
APC 1	168	± 17
APC 2	320	± 22

Table 2: Validity range of arc energy

4.2.8.3 Confirmation of test apparatus settings

Test apparatus settings shall be confirmed prior to each test (test distances, electrode gap, angle between the glove-test panels). The values of arc current, arc voltage, arc duration, arc energy and the direct exposure incident energy shall be recorded (with calibration shots prior to beginning the test series) in order to ensure proper waveform.

In addition, the ambient temperature and relative humidity shall be recorded. The influences of wind and airflow shall be prevented.

4.2.8.4 Preparing and conditioning the box

The box shall be prepared and conditioned prior to testing.

The box should be configured according to Fig. 3.

The box shall be maintained in a dry and „conditioned“ state.

The following instructions for preparing and conditioning must be complied with prior to testing:

- The „plaster box“ shall be dried in an oven at a temperature of about 60° for a period of 12 h. It shall be verified that the weight and the surface electrical resistance at the end of the preparation process have not changed more than 5%.
- An initial arc shot shall be performed on each new „plaster box“ prior to using it for calibration and testing.

The test box shall be cleaned after each arc shot by removing metal particles and sediments from the box surface. If the test box is made of plaster, it shall be cleaned after each arc shot and restored as closely as practical to its original condition by carefully removing a thin surface layer using appropriate means, such as with a brush or spatula. If, after cleaning, the test box is determined to be outside dimensional tolerances or becomes unusable, it shall be replaced.

NOTE: The maximum number of arc shots will be influenced by the material used in manufacturing the box.

4.2.9 Maintenance and care of the test apparatus

4.2.9.1 Care of the sensor surface

The sensor surface should be wiped immediately after each test and while still hot to remove any decomposition products that may have been deposited and potentially cause an error in the future. If deposits collect and appear to be uneven or thicker than the paint coating, then the sensor surface will require reconditioning. Once the sensor has cooled, it should be carefully cleaned with an acetone or petroleum-based solvent that facilitates a gentle treatment.

The surface should then be repainted with a thin coating of black, high-temperature spray paint. The same paint shall be used for all sensors. It must be ensured that the surface coating is dry prior to commencing the next test. The sensors shall be calibrated after undergoing reconditioning.

NOTE: Examples of the black paint can be Krylon™ BBQ & Stove paint 1618 or ARCHITECT Grillspray, 400 ml, Tec-Art Art.No./Code: J32 4 694

4.2.9.2 Care of the glove test panel

The glove test panel shall be maintained in dry condition. When testing is conducted outdoors with extensive intervals between testing, it shall be covered to prevent excess temperatures resulting from direct exposure to the sun.

4.2.9.3 Care of the electrodes

Electrodes shall be cleaned mechanically after each test shot. The surface must be smooth; molten metal and fuse wire fragments must be removed. The cleaning process shall ensure that the fuse wire has sufficient electrical contact to initiate the arc.

The required electrode gap of 30 mm ± 1 mm must be ascertained prior to each test. Electrodes shall be replaced if their arc characteristics are not maintained according to 4.2.5 and 4.2.8.2. Any arc shots that do not fulfil the characteristics shall be factored out as being invalid.

4.2.10 Test procedures

4.2.10.1 Test apparatus

The test box and glove test panel shall be configured according to Fig. 5.

4.2.10.2 Number of test specimens

For each type of protective gloves 3 pairs (6 individual test specimens) shall be tested during each test series.

If the palm and backside of a glove are made of different materials, then both sides shall be tested in separate test series.

Note: Different materials in palm and backside require twice as many test specimens

4.2.10.3 Test parameters

Test parameters are established for the following four characteristic protection classes:

Arc protection class	Test current kA	Test voltage V AC	Test distance mm	Arc duration ms
APC 1	4 ± 5%	400 ± 5%	300 ± 5	500 ± 5%
APC 2	7 ± 5%	400 ± 5%	300 ± 5	500 ± 5%
APC 1_150	4 ± 5%	400 ± 5%	150 ± 5	500 ± 5%
APC 2_150	7 ± 5%	400 ± 5%	150 ± 5	500 ± 5%

Table 3: Test parameters

NOTE: The calibrated test setups for APC 1 and APC 2 in Sec. 4.2.8.2 are used for performing the Arc protection class tests APC 1_150 and APC 2_150.

4.2.10.4 Test conditions and initial temperature

Testing shall be carried out at an ambient temperature T_a between 15 °C and 35 °C with a relative humidity of 25% to 75%.

The ambient temperature T_a and the initial sensor temperature T_o shall be measured. It must be ensured that the initial sensor temperatures are within a tolerance of $T_o = T_a \pm 2$ °C for the test series (when measuring the temperature difference by means of thermocouples). Decomposition products shall be removed. Active sensor surfaces shall be reconditioned on a regular basis.

NOTE: *If necessary, the sensors should be cooled with an air jet or contact with a cold surface. If condensed decomposition products are thicker than the paint coating, then the sensor should be cleaned with an acetone or petroleum-based solvent. The surface should be repainted with a coating of black colour. The same colour should be used for all sensors.*

NOTE: *If a test conducted outdoors requires suitable means to preclude the effects of wind, rain, etc., then testing shall begin no later than 5 min. from the time the specimen under test was removed from the pre-conditioning atmosphere.*

4.2.10.5 Mounting the test specimen

The protective glove shall be placed over the glove holders and fastened on the rear side of the panel by appropriate means (e.g. with clamps) in such a manner that there is no air gap between the calorimeter and the inner side of the glove (in close contact with the face of the calorimeter). The calorimeter should be centred directly behind the backside of the glove.

If the backside and palm of a glove type are made of different materials, then an additional testing series shall be carried out with the glove mounted in such a manner that the calorimeter is centred directly behind the palm of the glove.

NOTE: *If the manufacturer stipulates the use of undergloves, these shall be placed over the glove holders prior to mounting the protective glove under test.*

4.2.10.6 Performing the test

The arc shall be initiated within 5 minutes after the glove specimen was removed from the pre-conditioning atmosphere.

The point of arc ignition shall be reliably determined.

The arc energy values shall be determined for each individual test shot. A test shot is valid only if the arc energy W_{arc} lies within a permissible deviation from the mean value according to Table 2. Otherwise the test shot shall be repeated.

The progression of temperature rise for the 3 sensors shall be determined for each valid test shot (see 4.2.8.2). Temperature rise curves shall be plotted over the total evaluation period of 30 s for each test shot in a test (test series).

For each test shot, the value pairs (maximum temperature rise ΔT_p and the time to peak temperature t_{max}) shall be determined.

For each test shot, the heat curve $E_i(t)$ shall be calculated by multiplying the temperature rise curve by the sensor constant 5.52 kJ/m² °C (or 0.132 cal/cm² °C) according to 4.2.3.2 for the total exposure time of 30 s.

4.2.10.7 Evaluation of measurement results

The incident energy shall be calculated by multiplying the maximum temperature rise by the sensor constant 5.52 kJ/m² °C (or 0.132 cal/cm² °C).

$$E_{i0} = 5,52 \text{ (kJ/m}^2 \text{ °C)} \times \Delta T_{p0} \text{ (°C)} \text{ or } E_{i0} = 1,132 \text{ (cal/cm}^2 \text{ °C)} \times \Delta T_{p0} \text{ (°C)}$$

$$E_{it} = 5,52 \text{ (kJ/m}^2 \text{ °C)} \times \Delta T_p \text{ (°C)} \text{ or } E_{it} = 1,132 \text{ (cal/cm}^2 \text{ °C)} \times \Delta T_p \text{ (°C)}$$

The direct exposure incident energy E_{i0} from the calibration according to 4.2.8.2, the transmitted incident energy E_{it} and the difference energy ΔE_i for the six test specimens must be calculated for each test series. The mean value from the six ΔE_i values and the confidence range for this mean value are to be subsequently calculated for a statistical certainty of S = 95 %.

4.2.10.8 Sensor response versus Stoll curve

The Stoll curve¹, based on the incident energy (total heat values) according to Equation (1), shall be overlaid on the plot of the six value pairs (calculated transmitted incident energy E_{it} , see 4.2.10.7, and point in time of maximum temperature t_{max}), as well as on the plot of the six heat curves $E_{it}(t)$ of the transmitted incident energy (see 4.2.10.6).

$$E_{iSTOLL} \text{ [kJ/m}^2\text{]} = 50.204 \times t^{0,2901}, [t \text{ in s}] \quad (1)$$

The differences ΔE_i (see Equation (2)) between the respective transmitted incident energy values E_{it} and the Stoll limit value shall be determined for each test shot and the (six values) test.

$$\Delta E_i = E_{it}(t_{max}) - E_{iSTOLL}(t_{max}) \quad (2)$$

4.2.10.9 Assessment of test results

The test has been passed when, once the arc flash has extinguished:

- the afterflame time for each specimen is ≤ 5 s
- no melting through of the specimen is evident

¹ Stoll, A.M. and Chianta, M.A., Method and Rating System for Evaluation of Thermal Protection. Aerospace Medicine, Vol. 40, 1968, pp. 1232 – 1238.

- no hole formation greater than 5 mm on the specimen is evident
- all 6 value pairs (E_{it} , t_{max}) lie below the corresponding Stoll values and all of the transmitted incident energy $E_{it}(t)$ heat curves lie below the Stoll curve at any moment in time during the exposure period.

NOTE: *Difficulty in dismantling the test specimen from the glove test panel may indicate an increased degree of material shrinkage. This and other abnormalities should be noted in the Test report.*

4.3 Additional marking & identification

In addition to the marking of the protective gloves according to DIN EN 407, clause 7, the protective gloves shall be marked with the pictogram in Fig. 2.



Fig. 2 - Symbol, Protection against the thermal hazards of an electric arc (IEC-60417-6353 (2016-02))

References to this Principles of testing („GS-ET-42-2“) and the Protection class tested (e.g. „APC 2“) shall be applied adjacent to the symbol.

According to PPE regulations:

- CE marking with the number of the notified body that carried out the quality control according to Module C2 or Module D
- Month and year of manufacture
- Type, charge or serial number, or an identifying mark for identifying the PPE.
- Manufacturer's name, registered trade name or registered trademark, as well as the postal address where the manufacturer can be contacted.

4.4 Durability of markings

Marking durability is to be tested by rubbing them for 15 s with a water-soaked, lint-free cloth, and then rubbing them for 15 s with an ethyl alcohol (CH₃-CH(OH)-CH₃)-soaked, lint-free cloth.

NOTE: *It is not integral to this standard, to ensure that the relevant legal and safety requirements for the handling of these chemicals have been fully complied with.*

The test has been passed when the markings are still clearly legible and haven't rolled up or begun to detach.

4.5 User information

In addition to the information required according to DIN EN 407, the following information must be provided on the marking for identification:

- Explanation of the Protection class and the scope of application.

- The manufacturer must also provide warning notice that a burn risk cannot be excluded when a hand comes in direct contact with the electric arc.
- Explanation of the symbol; Protection against the thermal hazards of an electric arc
- Information regarding regular inspections

According to PPE regulations:

In addition to the name and address of the manufacturer, the instruction manual drawn up by the manufacturer must contain all relevant information related to the following points:

- a) Instructions regarding storage, use, cleaning, maintenance, servicing and disinfection. Cleaning, maintenance and disinfectant products recommended by the manufacturer must have no adverse effects on PPE or users when applied in accordance with the relevant instructions;
- b) performance as recorded during corresponding technical testing to check the levels or classes of protection provided by the PPE in question;
- c) if applicable, suitable accessories that must be used with the PPE (e.g. undergloves) as stipulated by the manufacturer;
- d) if applicable, the classes of protection appropriate to different levels of risk and the corresponding limits of use;
- e) if applicable, the obsolescence deadline or period of obsolescence of the PPE or certain of its components;
- f) if applicable, the type of packaging suitable for transport;
- g) the significance of any markings or identification (see No. 2.12).
- h) the risks against which the PPE is intended to protect;
- i) the location where the available directives or, if applicable, the Union harmonisation legislation can be found;
- j) The name, address and identification number of the notified body or bodies involved in the PPE conformity assessment process;
- k) the location where the applicable harmonised norm(s) applied, including the respective date(s), and/or other technical specifications used can be found;
- l) the Internet address at which the EC Declaration of Conformity can be found.

The information required under the points i, j, k and l does not need to be included in the manufacturer's instruction manual if the EC Declaration of Conformity is provided together with the PPE.

The manufacturer must specify the exclusive use intended of this type of PPE in its instruction manual.

The instructions and information must be provided in a language easily understood by the consumer and other end-users in accordance with the decision of the respective member state. The instructions and information must be clear, easily understandable and legible.

4.6 External materials and properties

No materials containing substances harmful to health may be used on any part of the protective gloves that comes in regular contact with the wearer's skin.

4.6.1 PAH

That portion of polycyclic aromatic hydrocarbons (PAH) used in that area of the protective glove that can come in contact with the wearer's skin must not reach a dosage level that could be harmful to health.

Test: Test of critical components according to the German AfPS GS 2014:01 PAK.

4.6.2 DMF

It must be checked to ensure whether the manufacturer has provided a declaration regarding the use of dimethylformamide (DMF). Based on the German Technical Rule for Hazardous Substances, TRGS 401: 2008, the maximum level of DMF must be less than 10 mg/kg of the material used for the inner lining.

Test: Review the manufacturer's declaration as submitted and check for completeness and compliance with the limit value.

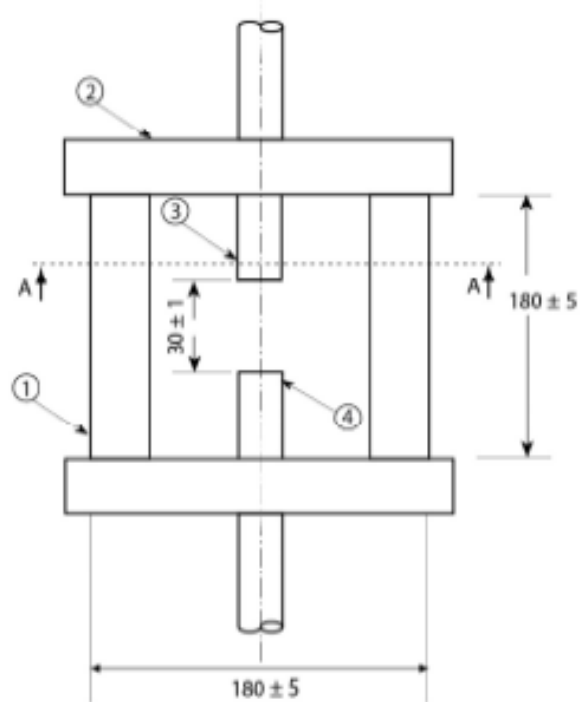

Front view

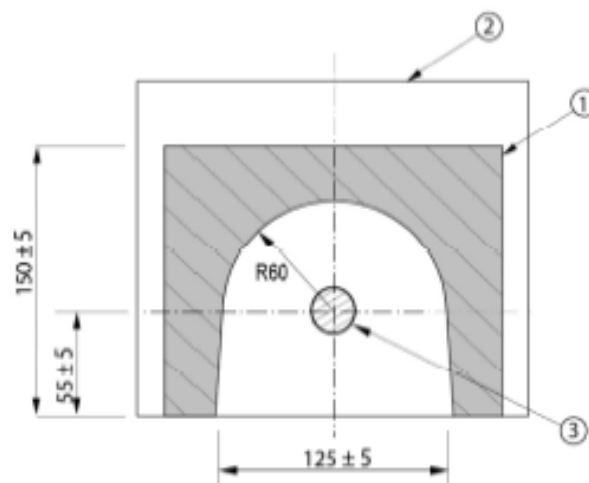

Top view – A-profile

Dimensions in mm

Fig. 3 Test box

Legend

- 1 Non-conductive, heat-resistant material (e.g. plaster)
- 2 Insulating plate, thickness > 15
- 3 Electrode $\varnothing 25 \pm 0.1$ (aluminium)
- 4 Electrode $\varnothing 25 \pm 0.1$ (copper)

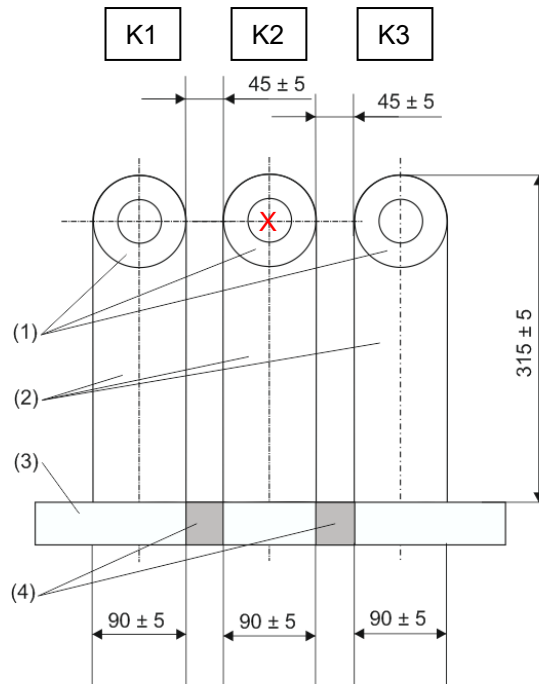
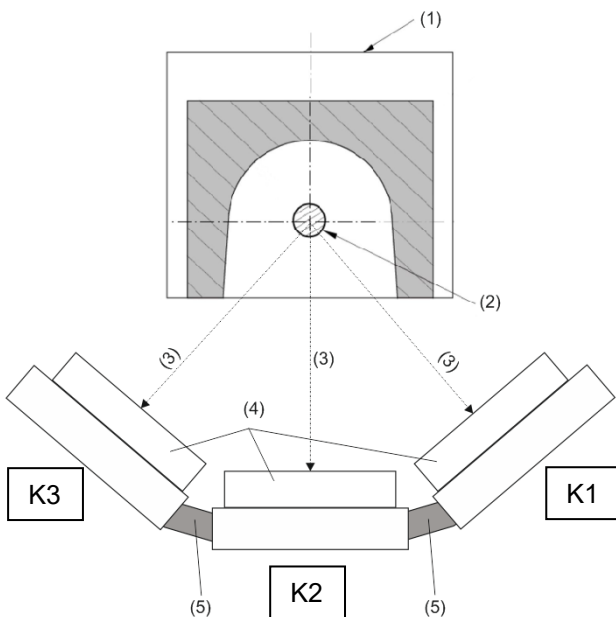

Fig. 4 Glove test panel (dimensions in mm)

Legend

- X The centre of the electrode spacing in the test box
 - 1 Calorimeter ISO 9151:1995
 - 2 Glover holders
 - 3 Attachment support (e.g. BOSCH profile 45x45)
 - 4 Swivelling connecting elements from the outer to the middle holders (e.g. BOSCH 45x45 joint support)
- K1, K2, K3 Designation of the individual panels



Legend

- 1 Test box
 - 2 Electrodes
 - 3 Test distance (150 ± 5 or 300 ± 5)
 - 4 Glove holders with calorimeters
 - 5 Swivelling connecting elements from the outer to the middle holders (e.g. BOSCH 45x45 joint support)
- K1, K2, K3 Designation of the individual panels

Fig. 5 Glove test panel (dimensions in mm)

5 Annexes

5.1 Directives / Regulations

- Regulation (EU) No 2016/425 of the European Parliament and of the Council of regarding Personal Protective Equipment from 9 March 2016

5.2 Standards

DIN EN 407:2004-11	Protective gloves against thermal risks (heat and/or fire)
ISO 9151:1995-05	Protective clothing against heat and flame - Determination of heat transmission on exposure to flame
DIN EN 61482-1-2:2015-08	Live working - Protective clothing against the thermal hazards of an electric arc – Part 1-2: Test methods – Method 2: Determination of arc protection class of material and clothing by using a constrained and directed arc (box test)